



1.3t-1.6t-1.8t-2t 3 Teker Elektrikli Forklift Teknik Özellikleri / 1.3t-1.6t-1.8t-2t 3 Wheel Technical Specifications

	Model	NB13S-MQJZ2	NB16S-MQJZ2	NB18S-MQJZ2	NB20S-MQJZ2			
Spesifikasyonlar/ Specification	1							
	2	Kontrolör tipi/ Controller type						
	3	Kapasite/ Rated capacity	kg	1300	1600	1800	2000	
	4	Yük merkezi/ Load centre	mm	500	500	500	500	
	5	Kaldırma yüksekliği/ Lifting height	mm	3000	3000	3000	3000	
	6	Serbest kaldırma yüksekliği/ Free lifting height	mm	-	-	-	-	
	7	Çatal ölçüsü/ Fork size	L x W x T	mm	920 X 100 X 35	920 X 100 X 35	920 X 100 X 35	920 X 100 X 35
	8	Tilt açısı/ Tilting angle	F/R (α°/β°)	°	6.5° / 6.5°	6.5° / 6.5°	6.5° / 6.5°	6.5° / 6.5°
Ebatlar / Dimensions	Toplam ölçüler/ Overall dimensions	Gövde uzunluğu/ Length to face of fork	mm	1879	1979	1979	2094	
		Genişlik/ Width	mm	1070	1070	1070	1140	
		Asansör kapalı yükseklik/ Height when mast lowered	mm	1975	1975	1975	1975	
		Asansör açık yükseklik/ Height when mast extended	mm	4010	4010	4010	4010	
	Kabin yüksekliği/ Height to safeguard	mm	1971	1971	1971	2011		
	Dönme yarıçapı/ Turning radius	Min.	mm	1543	1643	1643	1758	
	Ön çıkıntı/ Front overhang	mm	371	371	371	371		
	Lastik iz genişliği/ Tread	F/R	mm	924 / 186	924 / 186	924 / 186	924 / 186	
	Zemin açıklığı/ Ground clearance	Min.	mm	90	90	90	90	
	Dingil mesafesi/ Wheelbase	mm	1300	1400	1400	1515		
	Çatal açıklığı/ Fork spread	Min./ Max.	mm	200 / 890	200 / 890	200 / 890	200 / 890	
	Paletle çalışma koridor genişliği/ Working aisle width with pallet (Ast)	Palet Çapraz 1000x1200/ 1000x1200 crossways	mm	3240	3340	3340	3445	
Palet uzunlamasına 800x1200/ 800x1200 lengthways		mm	3364	3364	3464	3579		
Performans / Performance	Hız/ Speed	Sürüş (yükülü)/ Travel (Laden)	km/ saat(h)	13	13	13	13	
		Sürüş (yüksüz)/ Travel (Unladen)	km/ saat(h)	13	13	13	13	
		Kaldırma (yükülü)/ Lifting (Laden)	mm/ sn(sec)	300	290	280	255	
		Kaldırma (yüksüz)/ Lifting (Unladen)	mm/ sn(sec)	460	445	435	435	
	Tırmanma/ Gradeability	Yükülü/ Laden	%	15	15	15	15	
		Yüksüz/ Unladen	%	15	15	15	15	
	Serbest ağırlık/ Self weight	Akü dahil/ Include battery	kg	2820	3080	3140	3480	
	Lastik/ Tyre	Ön x 2/ Front x 2		18 X 7-8	18 X 7-8	18 X 7-8	200/50-10	
Arka x 2/ Rear x 2			15X4.5-8	15X4.5-8	15X4.5-8	15X4.5-8		
Motor	Sürüş motoru/ Driven motor	kw	4X2	4X2	4X2	4X2		
	Kaldırma motoru/ Pump motor	kw	9.2	9.2	11	11		
Akü/ Battery	Standart/ Standard	V/Ah	48 / 500	48 / 500	48 / 500	48 / 625		
Çalışma basıncı ataşmanlar için/ Operating pressure for attachments	Mpa		14.5	14.5	14.5	17.5		



3 tekerlekli Elektrikli Forklift

3 WHEEL ELECTRIC FORKLIFT

1.3t - 1.6t - 1.8t - 2t



a=200 mm yük mesafesi/ safety clearance

$$AST = a + \textcircled{14} + \textcircled{15} + \sqrt{W^2 + (B/2)^2}$$

Yük Grafiği/ Load Chart
Kaldırma Yüksekliği/ Lift Height ≤ 3000 mm

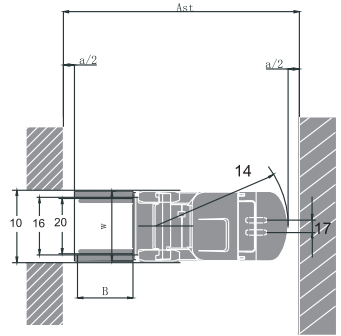
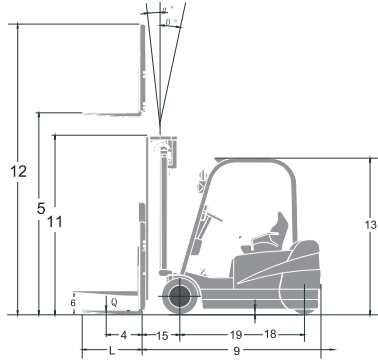
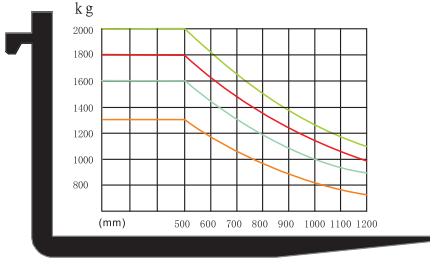

1.3t-1.6t-1.8t-2t 3 Teker Elektrikli Forklift Asansör Seçenekleri/1.3t-1.6t-1.8t-2t 3 Wheel Electric Forklift mast

Tip/ Type	Model	Maks. Çatal yüksekliği Max. Fork height mm	Toplam Yükseklik/ Overall height				Serbest kaldırma/ Free lift		Ön çıkıntı/ Front overhang mm	Tilt aralığı/ Tilt range		Kapasite/ Capacity		
			İndirilmiş/ Lowered mm	Yükseltilmiş/ Extended		Yük yaslama korkuluksuz/ Without backrest mm	Yük yaslama korkuluksuz/ With backrest mm	İleri FWD		Geri BWD	Yük kapasitesi 500 mm / Load capacity at 500 mm			
				Yük yaslama korkuluksuz/ Without backrest mm	Yük yaslama korkuluksuz/ With backrest mm						Tek lastik / Single tire			
											1.6 t	1.8 t	2.0 t	
kg	kg	kg												
Geniş görüş 2 kademeli asansör/ Wide view 2-stage mast	SM330	3300	2125	3810	4280	0	0	371	6.5	6.5	1600	1800	2000	
	SM350	3500	2225	4010	4480	0	0	371	6.5	6.5	1600	1800	2000	
	SM370	3700	2325	4210	4680	0	0	371	3.5	5	1600	1800	2000	
	SM400	4000	2525	4510	4980	0	0	371	3.5	5	1600	1800	2000	
	SM450	4500	2775	5025	5480	0	0	371	3.5	5	1400	1600	1800	
	SM550	5500	3325	6025	6480	0	0	371	3.5	5	1150	1200	1300	
Tam serbest 3 kademeli asansör/ Full free 3-stage mast	SFM300	3000	1975	3510	3965	1010	1450	371	6.5	6.5	1600	1800	2000	
	SFM330	3300	2125	3810	4265	1160	1600	371	6.5	6.5	1600	1800	2000	
	SFM350	3500	2225	4010	4465	1260	1700	371	6.5	6.5	1600	1800	2000	
	STFM435	4350	1975	4860	5330	995	1425	371	3.5	5	1500	1700	1900	
	STFM450	4500	2025	5010	5480	1045	1475	371	3.5	5	1400	1600	1800	
	STFM480	4800	2125	5310	5780	1145	1575	371	3.5	5	1300	1500	1650	
	STFM500	5000	2225	5510	5980	1245	1675	371	3.5	5	1250	1450	1500	
	STFM550	5500	2390	6010	6480	1410	1840	371	3.5	5	1150	1200	1300	
	STFM600	6000	2575	6510	6980	1595	2025	371	3.5	5	1050	1100	1200	
	STFM650	6500	2360	7010	7480	1710	2240	371	3.5	5	900	950	1000	